

RoHS Compliant

Rev.	Description/Eco	Date	By

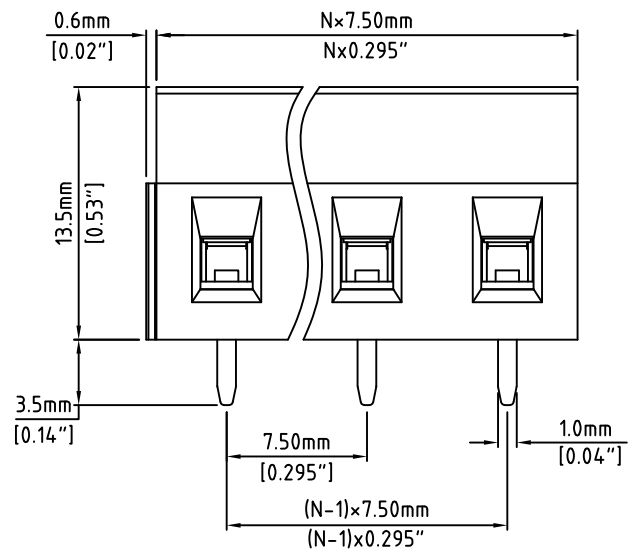

N=Number of Positions

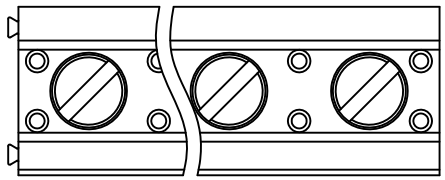
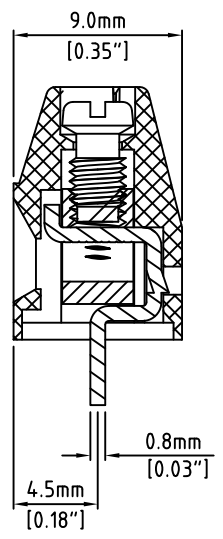

Material:	
Contact Block:	Brass, Ni Plated
Contact Solder Pin:	Brass, Tin Plated
Screw:	M3.0, Steel, Zinc Plated, "-" slotted
Insulating Body:	Polyamide, UL94V-0, Green
Electrical	
Voltage Rating:	300 VAC
Current rating:	16 AMPS
Withstand Voltage:	1500 VAC, Test time 60 sec
Wire Range:	12-28 AWG
Mechanical	
Torque:	3.5 lbs-in. Max
Operating Temperature:	-40°C to +115°C -40°F to +239°F
Soldering Temperature:	260°C, 500°F for 5 seconds
Safety Approval:	US

Part Number Configuration.

EB750-XX-500

Number of Positions: 5
Color: 5-Green

(Other Color Options Available)
Please consult Factory

Max Number of Positions = 16

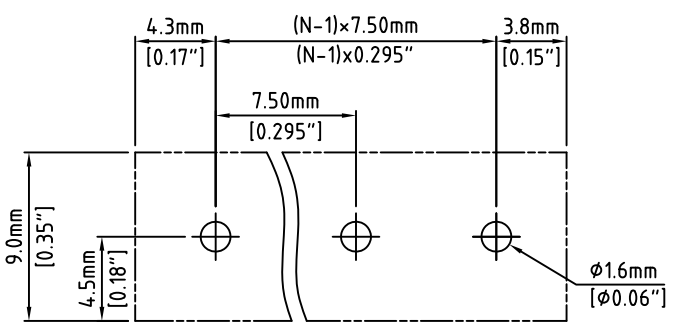

P.C.B. Layout

UNLESS OTHERWISE SPECIFIED BREAK ALL SHARP EDGES AND DEBURR ALL HOLES	TITLE:	7.50mm SPACING, CAGE CLAMP BLOCK
---	--------	----------------------------------

LIMITS: UNLESS OTHERWISE SPECIFIED HUND. ±0.02 FRACT. ±1/64 THOU. ±0.005 ANGLE ±1°	SCALE	THIS IS A CONFIDENTIAL DRAWING AND MUST BE TREATED AS SUCH. NO DISTRIBUTION IS ALLOWED WITHOUT WRITTEN APPROVAL BY EB750 ELECTRO INC.	Electro Inc. PLAINVIEW, NY 11803
---	-------	---	-------------------------------------

IMPORTANT DISCLAIMER: All information provided on this print is for reference. Always perform your own tests and acquire samples and further information to determine product suitability. While we make effort to provide accurate information, we cannot be responsible for errors either of omission or typographical. EB750 Electro, Inc. assumes no responsibility for the use or suitability of any product. All products and specifications are subject to change without prior written notice.

METRIC LIMITS ONE PLACE ±0.3 TWO PLACES ±0.10 ANGLE ±1°	DRAWN: JM CHECKED: _____ APPROVED: _____	DATE: 04/02/07 DATE: _____ DATE: _____	SIZE: A	DRAWING NUMBER: EB750-XX-500	REV.
--	--	--	---------	------------------------------	------