

RoHS Compliant

Rev.	ECO#	Date	By
B	1307-0319	03/21/19	MWP

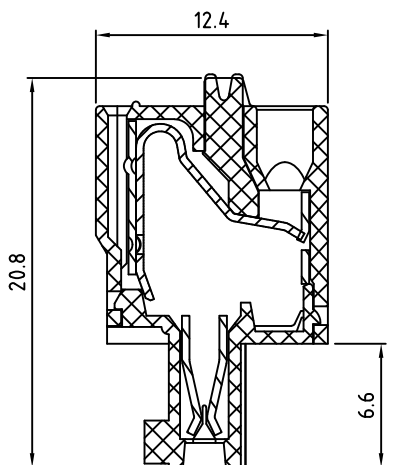
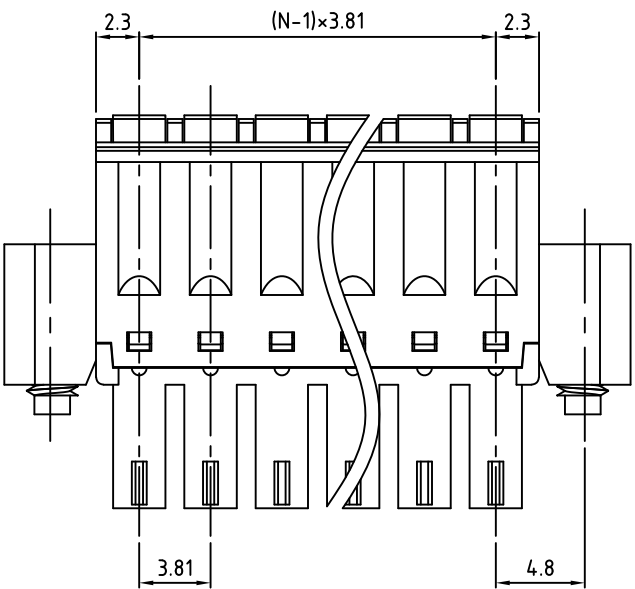
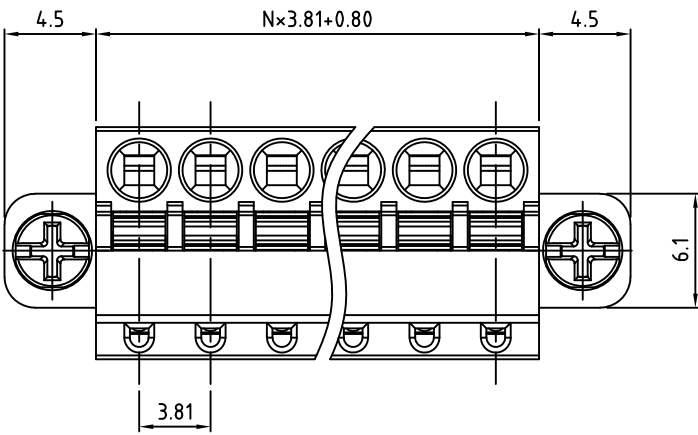

Material:	
Contact Block:	Brass, Tin Plated
Wire Retention Spring:	Stainless Steel
Insulating Body:	Polyamide, UL94 V-0, Green
Flange Screw:	M2.5, Steel, Zinc Plated
Electrical	
Voltage Rating:	300 VAC
Current rating:	8 AMPS
Withstand Voltage:	1500 VAC, Test time 60 sec
Wire Range:	14-28 AWG
Mechanical	
Operating Temperature:	-40°C to +115°C -40°F to +239°F
Soldering Temperature:	260°C, 500°F for 5 seconds
Safety Approval:	UL US

Part Number Configuration.
 EB452M-XX-500
 |
 Number of Positions

(Other Color Options Available)
 Please consult Factory

Max Number of Positions = 24

UNLESS OTHERWISE SPECIFIED BREAK ALL SHARP EDGES AND DEBURR ALL HOLES
 TITLE: 3.81mm SPACING, MOUNTABLE SCREWLESS PLUGGABLE BLOCK

LIMITS: UNLESS OTHERWISE SPECIFIED HUND. ±0.2 FRACT. ±1/64 THOU. ±0.05 ANGLE ±1°	SCALE	THIS IS A CONFIDENTIAL DRAWING AND MUST BE TREATED AS SUCH. NO DISTRIBUTION IS ALLOWED WITHOUT WRITTEN APPROVAL BY EBYP ELECTRO INC.	 PLAINVIEW, NY 11803
---	-------	--	--

IMPORTANT DISCLAIMER: All information provided on this print is for reference. Always perform your own tests and acquire samples and further information to determine product suitability. While we make effort to provide accurate information, we cannot be responsible for errors either of omission or typographical. EBYP Electro, Inc. assumes no responsibility for the use or suitability of any product. All products and specifications are subject to change without prior written notice.	METRIC LIMITS ONE PLACE ±0.3 TWO PLACES ±0.10 ANGLE ±1°	DRAWN JM CHECKED _____ APPROVED _____	DATE 07/26/07 DATE _____ DATE _____	SIZE A	DRAWING NUMBER: EB452M-XX-500	REV. B
---	--	---	---	-----------	----------------------------------	-----------